

PROSYSTEM[®]

Aluminium Light Crane System

**Simple,
but true**

Intelligent profile geometry
+ Unique composite trolleys
= **Amazingly light movement**

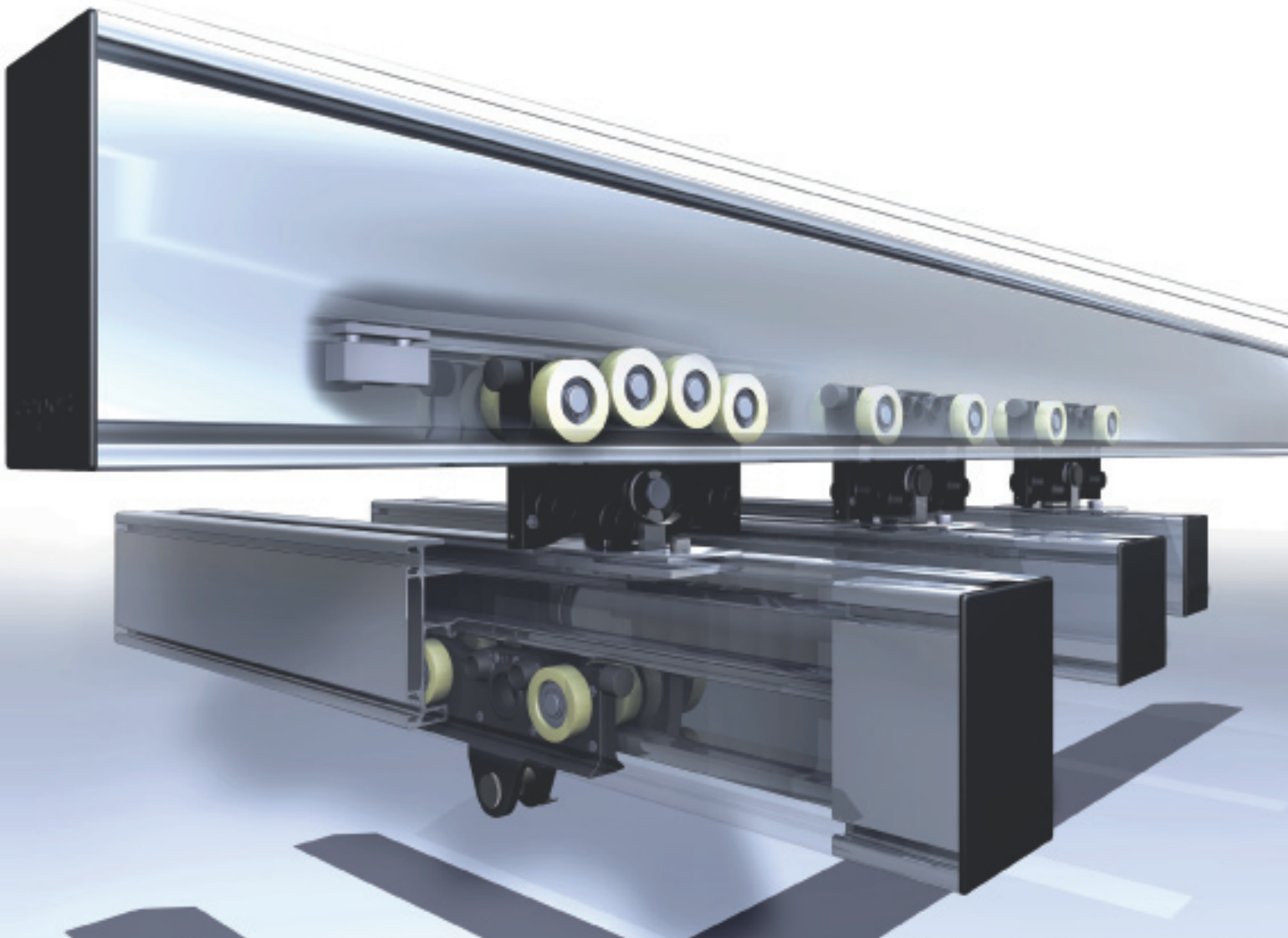

PROSYSTEM® Aluminium Light Crane System

ERIKKILA aluminium profiles are characterised by their intelligent profile geometry. The wide range of accessories can be used with all profile sizes. The system is thus flexible and economical to implement.

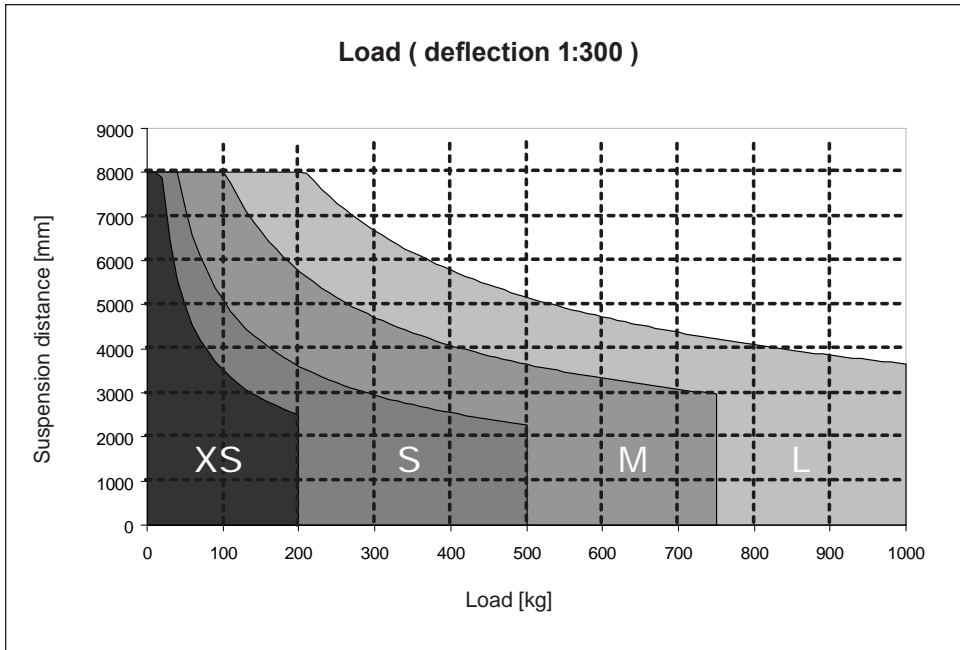

Calculation of suspended load:

$$G_0 = G_{\text{Load}} + G_{\text{Gripper}} + G_{\text{Lifting apparatus}} + G_{\text{Runners}} + G_{\text{Crane supports}}$$

Technical Data

Profile	XS	S	M	L
Weight (kg/m)	3,00	5,00	7,00	8,50
Elastic modulus (Wx)	24,80 cm ³	43,40 cm ³	84,70 cm ³	133,10 cm ³
Moment of inertia of area (Ix)	112,40 cm ⁴	233,40 cm ⁴	598,00 cm ⁴	1204,70 cm ⁴
Cross-section	11,42 cm ²	18,49 cm ²	25,73 cm ²	31,68 cm ²



The chassis is made of glass fibre, a strengthened plastic, and can be used, depending upon execution, for loads up to 500 kg.

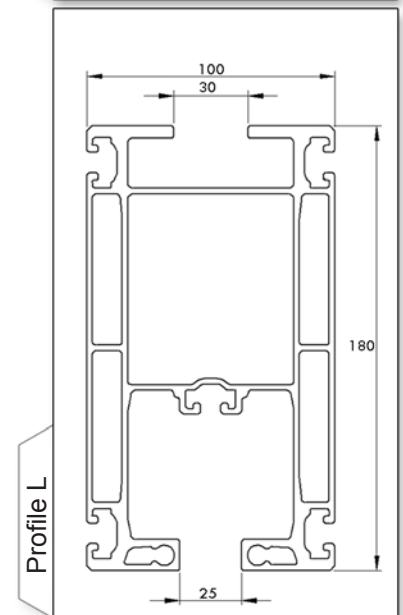
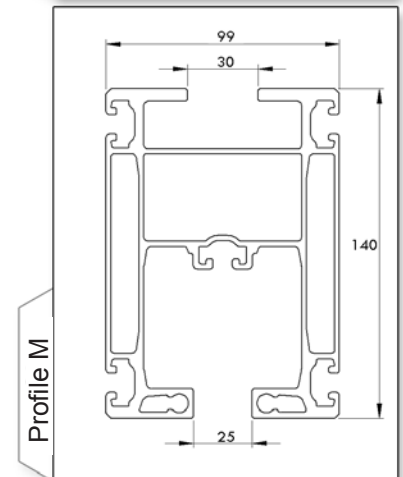
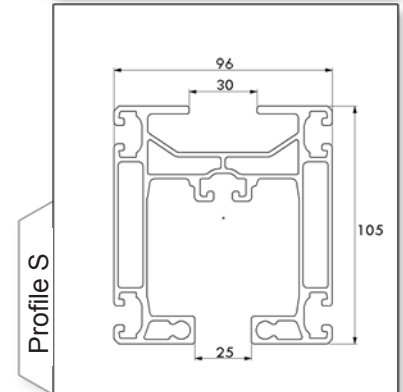
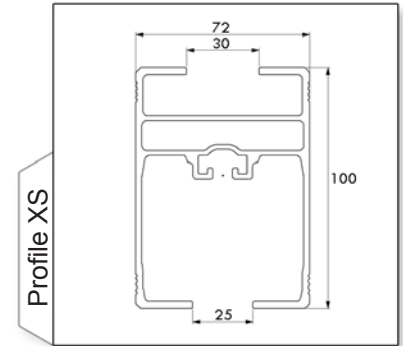

The following should be considered with regards to the profile impact and the ends of the profile:

1. The overall height of the suspension and the individual profile.
2. The distance of the profile link from the closest suspension point (D_s).
3. The projection of the profile beyond the last suspension point (P_{max}).
4. The distance of the centre of the travelling frame to the end of the profile (F_{min}).

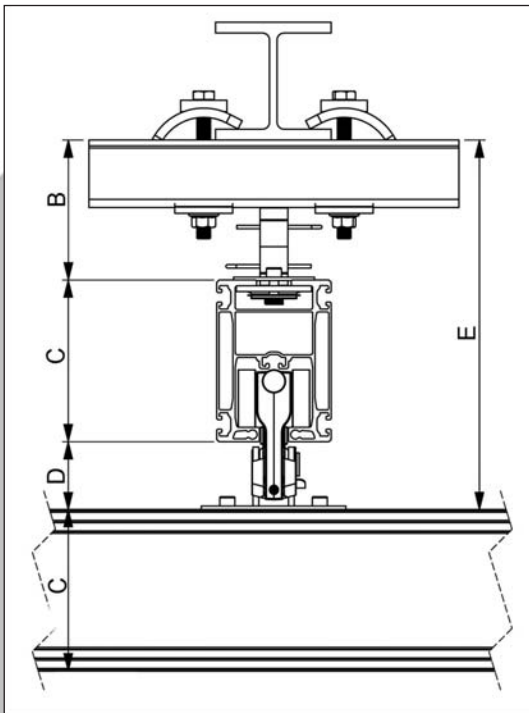
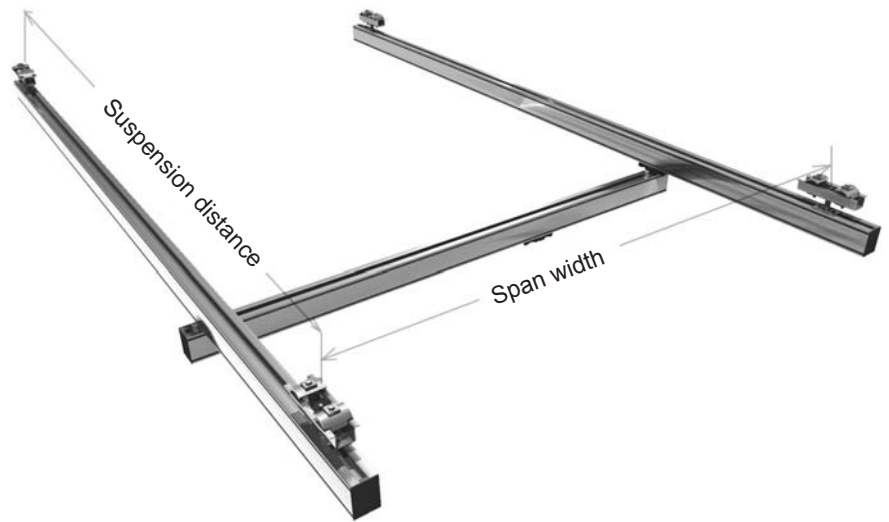

Profile	$B_{min.} / B_{max.}^*$	C	D	$E_{min.} / E_{max.}$
XS	121 / 211	100	60	280 / 660
S	121 / 211	105	60	285 / 665
M	121 / 211	140	60	320 / 700
L	121 / 211	180	60	360 / 740

* Special lengths on inquiry (max. 500 mm)

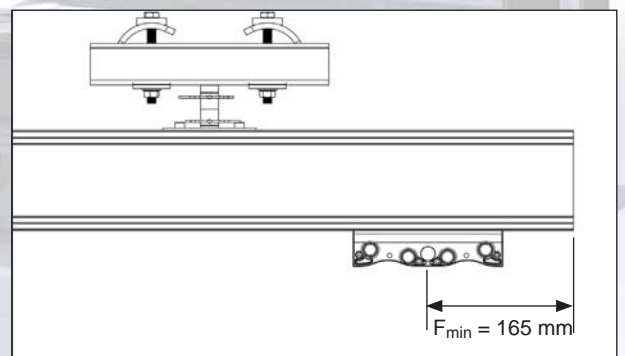
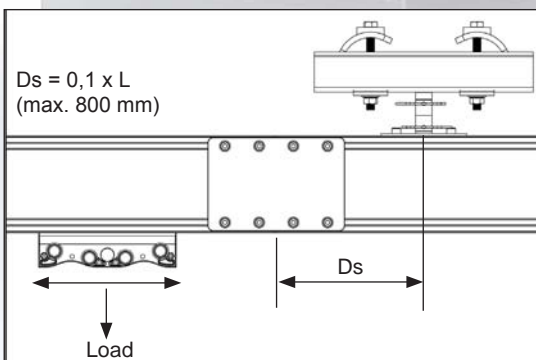
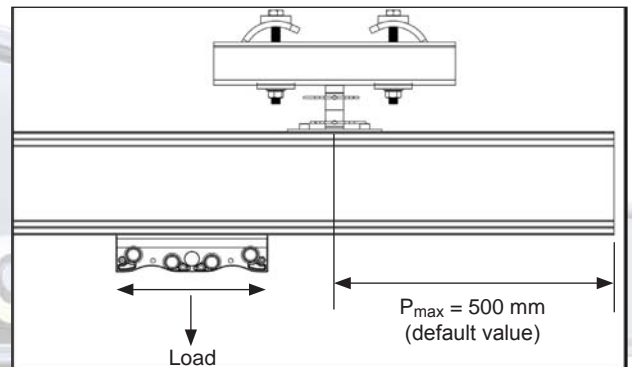

Subject to changes.

ERIKKILA®

PASSION IN CRANES

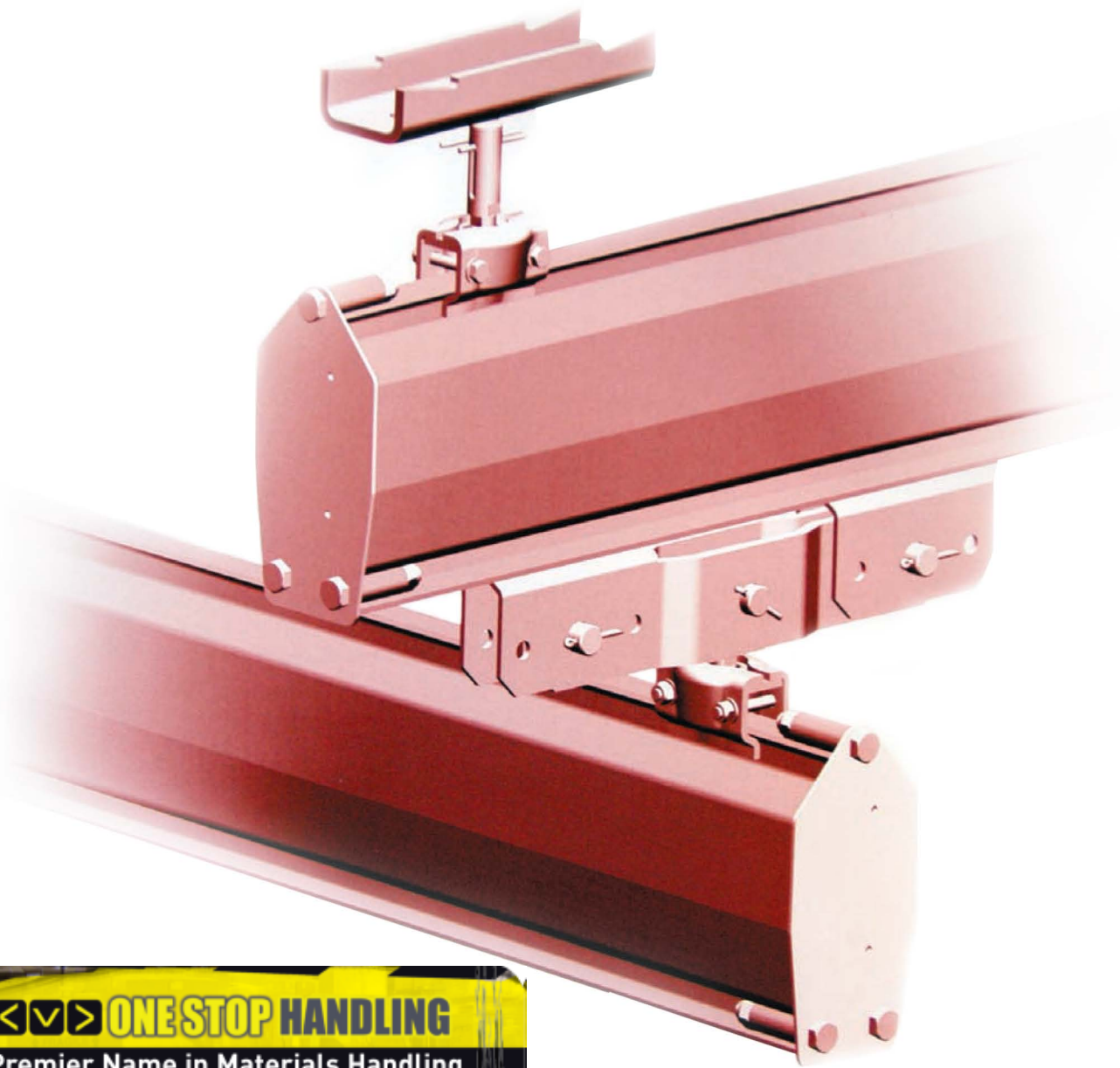

ONE STOP HANDLING

The Premier Name in Materials Handling

17 Primeside Park, Northwest Business Park, Dublin 15.

Tel: +353 1 864 9008 Mob: +353 87 0505 213

Email: info@onestophandling.ie Web: www.onestophandling.ie

[Finland] Sales and Factory

Erikkilä Nostotekniikka Oy

Masalantie 225

FI-02430 MASALA

T: +358 9 2219 0530

F: +358 9 297 5021

E: sales@erikkila.com

[Sweden] Sales Office

Erikkila AB

Metallgatan 17B

SE-262 72 ÄNGELHOLM

T: +46 431 452 650

F: +46 431 802 64

E: ab@erikkila.com

[Estonia] Sales and Factory

OÜ Eesti Kraanavabrik

Tähetorni 21 A

EE-11625 TALLINN

T: +372 6755 070

F: +372 6755 071

E: kraana@erikkila.com

[Russia] Sales Office

OOO Erikkila

Ul. Vozrogdenia 31 A, Office 204

198188 ST. PETERSBURG

T: +7 812 332 2843

F: +7 812 332 2843

E: ooo@erikkila.com

www.erikkila.com