

# OT900

BATTERY-POWERED ELECTRIC TUG

ZERO EMISSIONS

QUIET



**Folding and height adjustable tiller** for better comfort of use



**Butterfly accelerator**, easy to control with your thumb



**Battery charger on board**, display with light indication of charge status



**Pivoting wheel** allows a minimum of space to steer



MADE IN ITALY

The OT-900 is a towing equipment, with three wheels and tiller steering. It has been designed to easily move trailer trolleys and other containers on wheels, in safety and comfort, reducing physical stress and improving productivity. Many configurations are possible by choosing among different types of batteries and tires. It can be fitted with several accessories that make the standard product adaptable to many uses.



Material Handling Solutions

One Stop Handling Ireland Limited  
Unit 5 Keggpoint Business Park, Todernount Drive, Dublin 11, Ireland  
Tel: 01 864 9008 Email: info@onestophandling.ie Web: www.onestophandling.ie

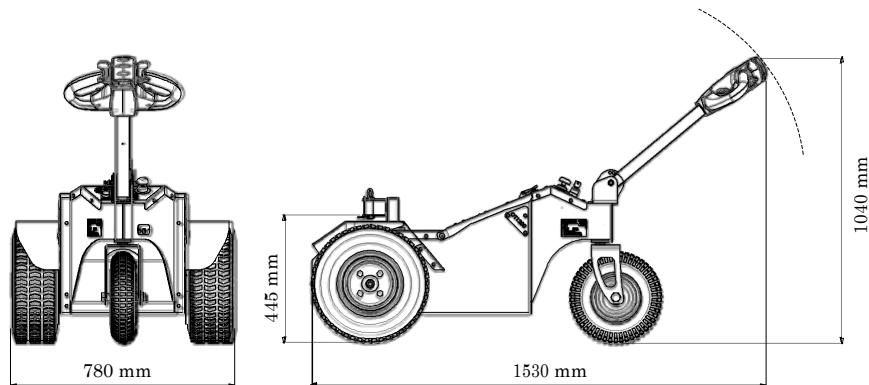

### FEATURES

Equipment body	<b>3 wheels</b>
Driving wheels on differential	<b>Garden type</b>
Driving control type	<b>Foldable tiller</b>
Accelerator	<b>Butterfly type</b>
Hook height	<b>430 mm abt</b>
Battery charger	<b>On board, 13 A High Frequency</b>
Dashboard display	<b>Remaining battery charge</b>
Parking brake	<b>Electromagnetic with the possibility of release</b>
Batteries	<b>Flooded 2 x 12V/72 Ah C20 (or AGM 2 x 12V/85 Ah C20)</b>
Elektromotor	<b>OT900 24V/900 Watt S1</b>
	<b>OT1200 24V/1200 Watt AC S2 60 min</b>
Product net weight	<b>178 kg abt</b>

### PERFORMANCES

Weight movement capacity on flat surface up to*	<b>3000 Kg</b>
Pulling speed	
Fast	<b>5 Km/h abt</b>
Slow	<b>2,5 km/h abt</b>
Pushing speed	
Fast	<b>3 Km/h abt</b>
Slow	<b>1,5 Km/h abt</b>
Battery recharging time	<b>8 hours abt</b>

\*The weight movement capacity is an indication., that can change with different machine fittings and working conditions (type of ground,wheel type,use of ballast,etc.)

Features shown are subject to change without notice

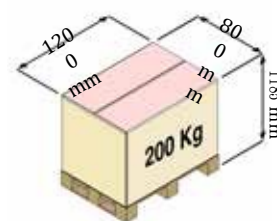

### ACCESSORIES

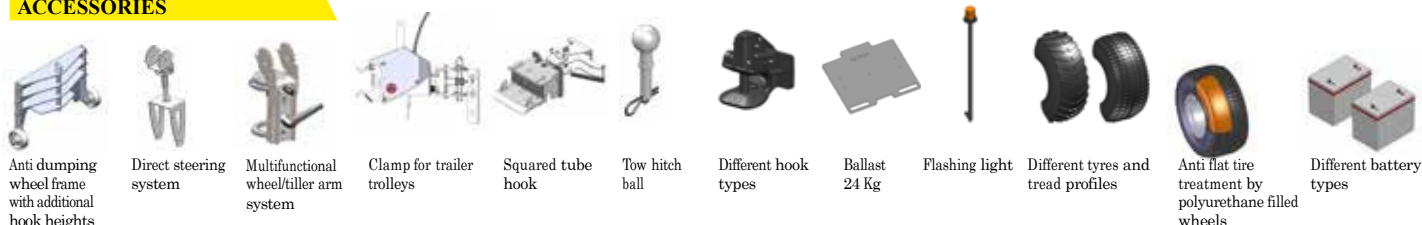

Anti dumping wheel frame with additional hook heights

Direct steering system

Multifunctional wheel/tiller arm system

Clamp for trailer trolleys

Squared tube hook

Tow hitch ball

Different hook types

Ballast 24 Kg

Flashing light

Different tyres and tread profiles

Anti flat tire treatment by polyurethane filled wheels

Different battery types