

JT300L-P

BATTERY-POWERED ELECTRIC CARRIER ON WHEELS
FOR LOADS **UP TO 500 KG***

ZERO EMISSIONS**QUIET****LOW MAINTENANCE**

**Flatbed with
removable sides**



**Equipment body on
4 wheels** for better
stability on rough
surfaces



**Tilting tiller with micro
safety switch and
automatic return to rest
position**



**Precise handling thanks
to the two steering
wheels on swing axle**

MADE IN ITALY

The JT-300LP is a four wheels carrier. The tilting tiller, which acts on the steering wheel, offers great control and easy handling. It has an accelerator operated by the thumb, allowing the use of only one hand. This carrier is ideal for both indoor and outdoor work, in greenhouses and in nurseries. It can push or pull without effort. The 260-liter flatbed is perfect for the rail industry, in Primary care trust centers, in hotels, in greenhouses and nurseries, for gardening and in livestock paddocks.

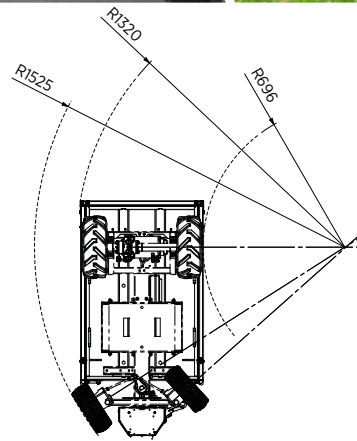
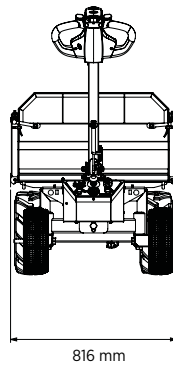
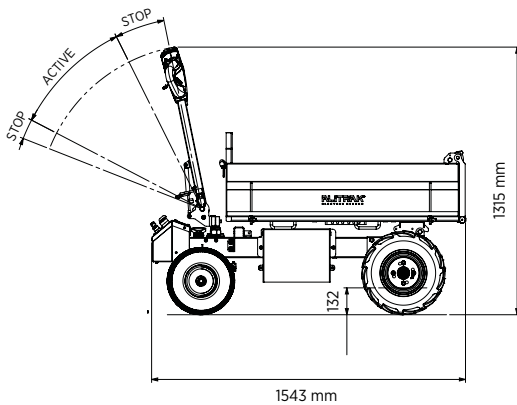

FEATURES

Equipment body	4 wheels
Driving wheels on differential	Garden type
Driving control type	Tiller
Accelerator	Butterfly type
Battery charger	External, 13A High Frequency
Dashboard display	JT300L-P Remaining battery charge JT300L-S Equipment failures JT300L-E Hour meter
Parking brake	Electromagnetic
AGM batteries	2 x 12V/85 Ah C20
Electric motor	JT300L-P 24V / 1200 Watt S2 60 Min. JT300L-S 24V / 900 Watt S1. JT300L-E 24V / 600 Watt S2 20 Min.
Product net weight	from 173 kg abt

PERFORMANCES

Loading capacity on flat surfaces*	JT300L-P 500 kg JT300L-S 400 kg JT300L-E 300 kg
Max gradient*	20%
Forward speed:	
Fast	5 Km/h abt
Slow	2,5 km/h abt
Reverse speed:	
Fast	3 Km/h abt
Slow	1,5 Km/habt
Battery recharging time	8 hours abt

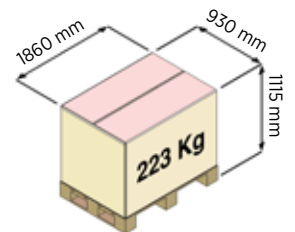

*The loading capacity is an indication that can change depending on the type of surface, on the slope degree and on the working time of the machine.

Features shown are subject to change without notice

ACCESSORIES



Electric lifter for flatbed tipping



Different tyres and tread profiles



Anti flat tire treatment by polyurethane filled wheels

onestophandling.ie

01 864 9008

info@onestophandling.ie