

DT300E

BATTERY-POWERED ELECTRIC WHEELBARROW
FOR LOADS **UP TO 300 KG***

ZERO EMISSIONS

QUIET

LOW MAINTENANCE



Semi automatic skip tipping



Direction change (forward-reverse) by switch on handlebars



Speed switch to operate in narrow spaces and on slopes



Different skip types available

MADE IN ITALY

The DT-300E is a wheelbarrow, with three wheels and a strong steel structure. It is designed to work in municipalities, graveyards, horse and other animal farms, greenhouses and nurseries. It has a semi-automatic mechanism for tilting the skip, activated by a switch on the handlebar. There are different tire and skip types available, allowing an ideal use on the grass or indoor.



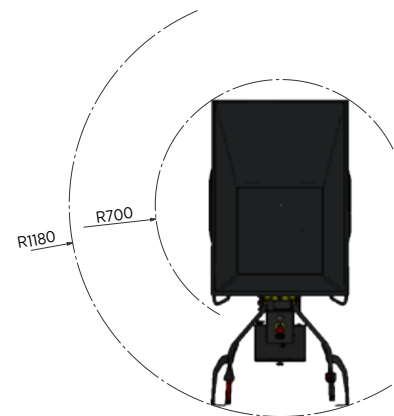
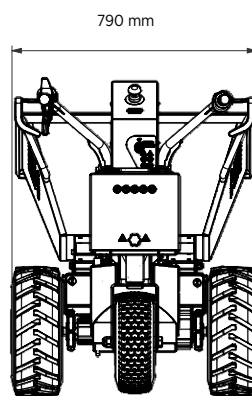
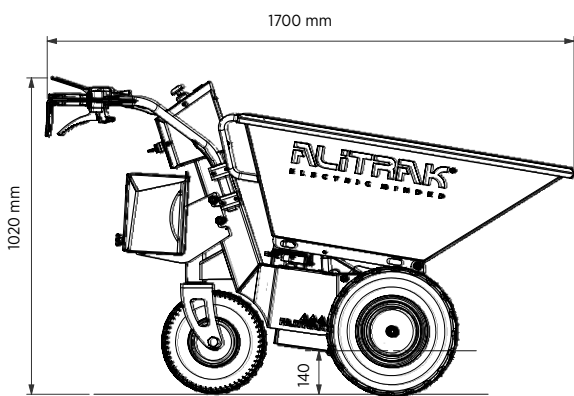

FEATURES

Equipment body	3 wheels
Driving wheels on differential	Tractor type
Skip	Steel 180 lt. capacity
Driving control type	Handlebars
Accelerator	Hand-grip type
Direction change	Switch on handlebars
Battery charger	External, 13A High Frequency
Dash board display	Remaining battery charge
Parking brake	Electromagnetic
AGM batteries	2 x 12V/85 Ah C20
Electric motor	24V / 600 watt S2 20 min.
Product net weight	163 kg abt

PERFORMANCES

Loading capacity on flat surface *	300 kg
Max gradient*	20%
Max forward speed:	
Fast	5 Km/h abt
Slow	2,5 Km/h abt
Max reverse speed:	
Fast	3 Km/h abt
Slow	1,5 Km/h abt
Battery recharging time	8 hours abt

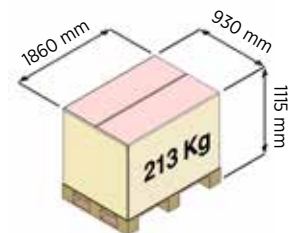

*The loading capacity is an indication that can change depending on the type of surface, on the slope degree and on the working time of the machine.

Features shown are subject to change without notice

ACCESSORIES



Plastique skip 330 lt.
200kg loading capacity



Anti flat tire treatment by
poliurethane filled wheels



Different tyres and tread
profiles

onestophandling.ie

01 864 9008
info@onestophandling.ie